



This electric/hydraulic pump is a two-stage, continuous pressure (demand) pump that contains all the necessary controls and circuitry for powering any single- or double-acting continuous pressure cylinders. It has an external pressure regulator, infinitely adjustable throughout the operating pressure range of 1,000 to 6,500 PSIG. An internal safety relief valve prevents damage from exceeding the maximum rated pressure.

It's a gear/axial piston pump designed for use in single or multiple station applications. Its high torque universal motor is low voltage tolerant. Includes 3/8" NPTF outlet ports. Shipped with two gallons of oil.

Features:

- CSA approved model available
- Drip proof universal motor
- Filtered filler/breather cap
- Liquid filled gauge
- Carrying handle
- 2.5-gallon metal reservoir
- 525 cu. in. usable oil
- Oil flow at max. pressure: 100 cu. in./min.

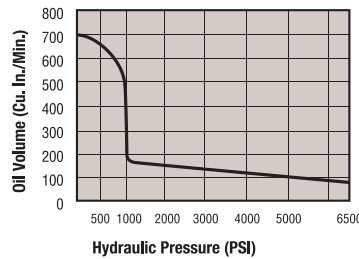

Performance
— No. PE1204FR

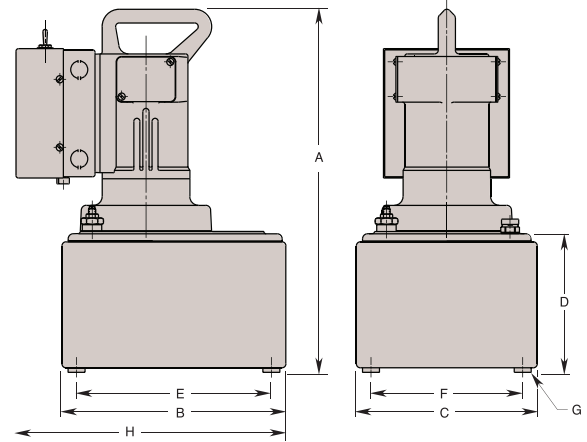

Catalog Number	Specifications			Dimensions (In Inches)							
	Electric Motor	Supply Voltage	Noise Level @ Idle/Maximum Pressure (DBA)	A	B	C	D	E	F	G Thread Size	H
PE1204FR	1½ hp; 12,000 rpm; 115 VAC; 25 amps max.; 50/60 Hz; single phase	115 VAC	80/85	18.250	12.500	10.500	7.000	10.000	8.000	½-20 UNF	14.000
PE1204FR-230	1½ hp; 12,000 rpm; 230 VAC; 14 amps max.; 50/60 Hz; single phase	230 VAC									

NOTE: Optional fluid level / temperature gauge is available, contact factory.

PT-FRPE1204

Tel: 800.541.1418
 powerteam.com
 info@powerteam.com

